

SUSTAINABLY SHAPING THE FUTURE

ENVIRONMENTAL REPORT 2022



SUSTAINABLY SHAPING THE FUTURE

ENVIRONMENTAL REPORT 2022

Dear Friends and Partners,

Ever since the Vauth-Sagel Group was founded, we have gladly accepted the human and environmental responsibility that comes with building a company. For us, it has always been clear how important it is to not only consider our economic success but also our ecological success, if we want to create a world worth living in for ourselves and our children.

That's why we can proudly say that sustainability is firmly anchored at the core of our business. Concrete measures at all our locations show that with ambition and innovation, it's possible to move mountains. A 50% energy saving by switching to LED lighting, a 44% energy saving by optimising the compressed air system and a 35% reduction in resource consumption with powder coating clearly indicate where our path leads: to an efficient, sustainable, circular economy that, in turn, results in a healthy environment with clean water, fertile soil and pure air.

We are pleased to lead the way down this path and look forward to introducing Vauth-Sagel's sustainability measures on the following pages.

**Heinrich Sagel, Heinz-Otto Sagel, Thomas Sagel, Claus Sagel,
Peter Sagel and Dr. Martin Sagel**

SUS ABI

TAIN- LITY

- 01 // Saving energy
- 02 // Generating energy
- 03 // Using raw materials intelligently
- 04 // Preventing waste
- 05 // Creating value
- 06 // Helping the environment
- 07 // Seizing the future
- 08 // Taking responsibility

AT THE CENTRE OF OUR BUSINESS

As a family company with a 60-year tradition, our responsibility towards people and the environment is inseparable from our economic success. Resource-efficiency, which means saving energy, preventing waste and using raw materials wisely, is one of the fundamental principles of our business. In our efforts

to leave future generations a world worth living in and actively shape its realisation, we find ourselves in complete agreement with the Sustainable Development Goals (SDG) of the United Nations and the German resource-efficiency programme, ProgRess III.



- ¹ Erkeln
- ² Paderborn
- ³ Korbach
- ⁴ Beverungen

ENVIRONMENTAL GOALS FOR OUR LOCATIONS

Ultimately, it's not words that count, but deeds. With this in mind, it was important to us to align our company strategy with the compass point of sustainability from early on. We have extensively invested in the ongoing implementation of resource-saving measures at all the sites in the Vauth-Sagel Group, and will continue to do so. We are aware that developing into an efficient, closed circular economy with next-to zero emissions and waste is a never-ending process. New technologies will continue to offer fantastic new opportunities. We look forward to setting yet more ambitious environmental goals in future, and transparently sharing our successes in our environmental report.

SAVING ENERGY

CONTINUALLY CONSUMING LESS

01 // Energy-efficiency is an issue that affects everyone at the moment, and businesses in particular. Due to rising costs, the ability to exploit every possible saving is both an ecological necessity and a prerequisite for profitable production. Within the Vauth-Sagel Group, we have long examined all our energy-consuming processes under the microscope, from heating and lighting to compressed air and logistics, and replaced or optimised them with viable alternatives.

10

1.1 Heating with gas and good ideas

We saved approx. 200 t CO₂ per year in the plant at our company headquarters in Brakel-Erkeln by switching our heat supply from heating oil to natural gas. At the same time, we renewed our heating system at the Korbach plant and switched to state-of-the-art condensing boiler technology. This strategy reduced the consumption of fossil fuels by 16% at this site alone. Further savings have been achieved by generating our own electricity and heat using innovative cogeneration units and boilers.



Up to
60 %
AVERAGE ENERGY SAVING



1.2 A shining example – LED

LED lights offer considerable advantages over conventional lighting. They consume far less energy, last a long time, and are considered a key technology in realising a green future. The conversion of our exterior lighting and factory lighting confirmed these claims with average energy savings of 50–60%. In addition, the sensor-controlled LED system switches on and off according to user presence, and adapts to the daylight conditions.

10

” Digitalisation and networking on all levels is the indispensable foundation for seamless data collection, analysis and continuous improvement processes.



1.3 Smart management – Factory 4.0

Digitalisation and networking on all levels is the indispensable foundation for seamless data collection, analysis and continuous improvement processes. As well of 24h monitoring of energy data using natural gas, heat quantity and electricity meters, the intelligent and

automated management of all energy-related processes is a key factor in certifiable sustainable production. For example, energy savings of approx. 5% have been achieved at the Korbach plant by replacing and optimising the building control and management systems.

1.4 Efficient and cold as ice – Our new cooling supply

The cooling supply for our injection moulding machines at the Paderborn site has been switched to free cooling/cogeneration and cold absorption, combined with a cooling well. Improved cooling performance results in reduced production cycle times and energy consumption.



10



44%

Energy saving by fixing leaks

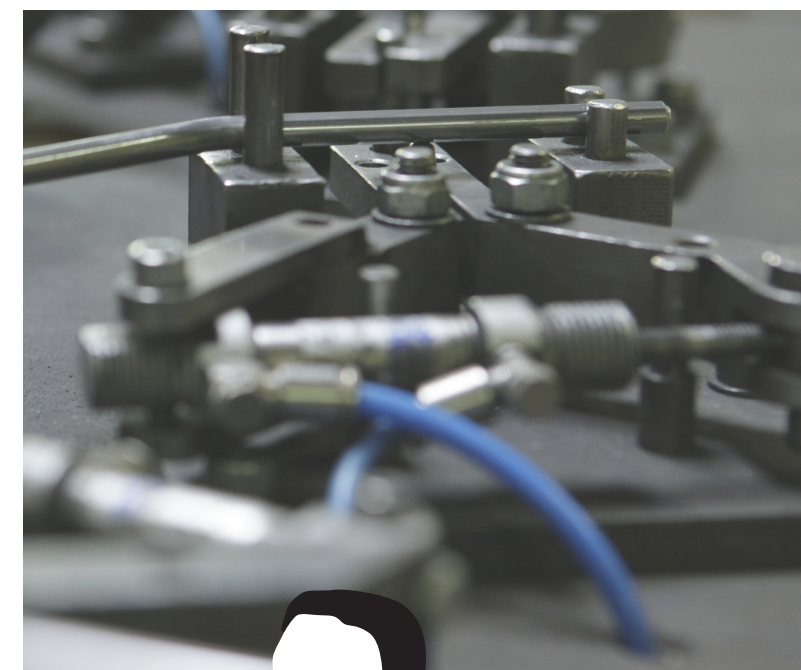
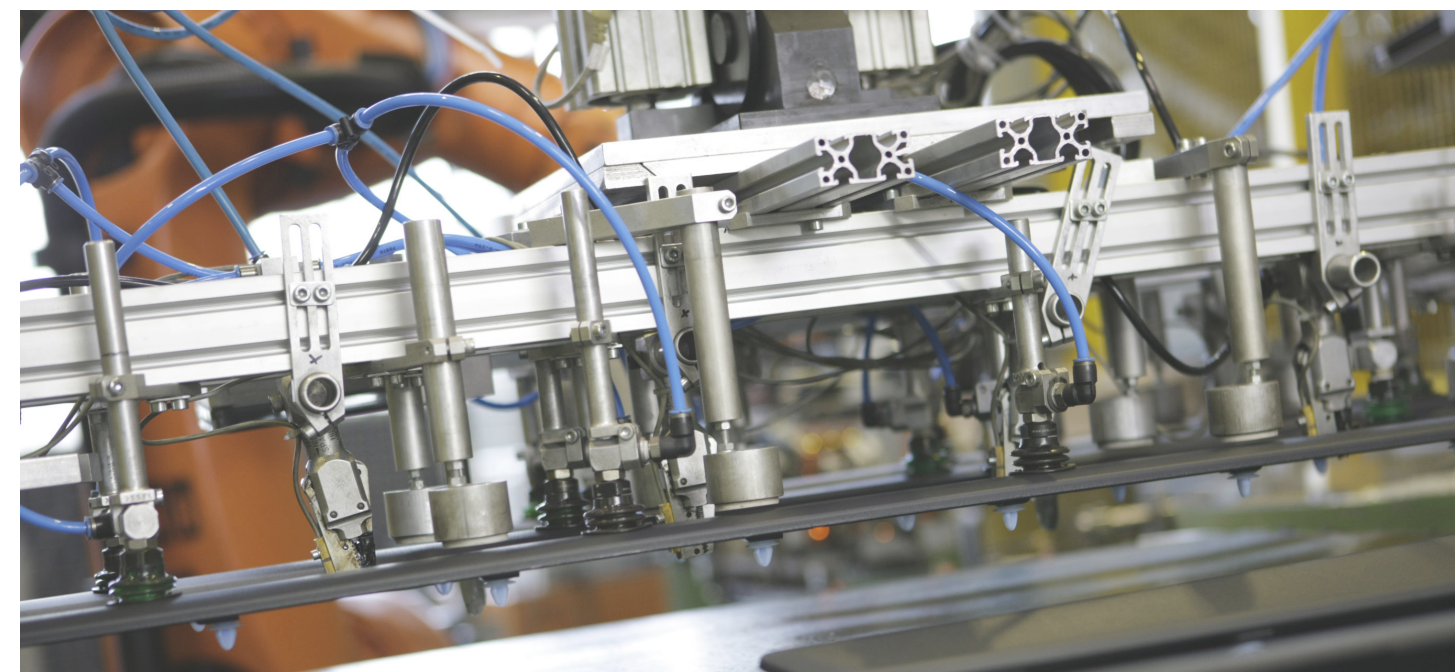

1.5 Room for improvement – Compressed air system optimised

Alongside electricity, compressed air is the most important industrial energy source. While wasted compressed air, e.g. through leaks, is barely perceptible to the untrained eye, analysis and optimisation of the compressed air system can achieve remarkable savings.

In the process of modernising the compressed air supply with state-of-the-art compressors, heat is even recovered and fed back into the heating system. The systematic identification and elimination of leaks results in energy savings of 44%.

1.6 Constant streamlining – Machinery

Not least, modern production technology is rapidly developing in terms of energy efficiency. By regularly investing in our machinery, we are continuously improving the environmental footprint of the energy used in our production.



10



” **To save fuel and prevent unnecessary trips, we are renewing our fleet with the most efficient tractor units on the market.**

1.7 Ecologically in the fast lane – Logistics

After the energy sector and industrial sector, transport is the third-biggest generator of greenhouse gases in Germany. Around 20% of all CO₂ emissions come from the trucks on our roads – a good reason for us to regularly bring our own logistics up to scratch in terms of energy consumption. To save fuel and prevent unnecessary trips, we are renewing our fleet with the most efficient tractor units on the mar-

ket. An intelligent telematics system provides the necessary data for optimal route planning, while the Mercedes-Benz Fleetboard seamlessly tracks fuel consumption and supports our drivers in driving economically. As well as ecologically optimising our HGV fleet, we have also introduced the first electric vehicles in our car fleet, including charging infrastructure.

10

GENERATING ENERGY

PRODUCING OUR OWN ELECTRICITY

02 // On the one hand, we are reducing our consumption of resources to the technically feasible minimum, while on the other hand, we are seizing every opportunity to generate our own energy and systematically moving towards a zero-sum energy footprint. This is our vision. With state-of-the-art cogeneration units, photovoltaic systems, heat recovery technologies and recycling of waste to generate energy, we are using innovative solutions to achieve our goal, one step at a time.

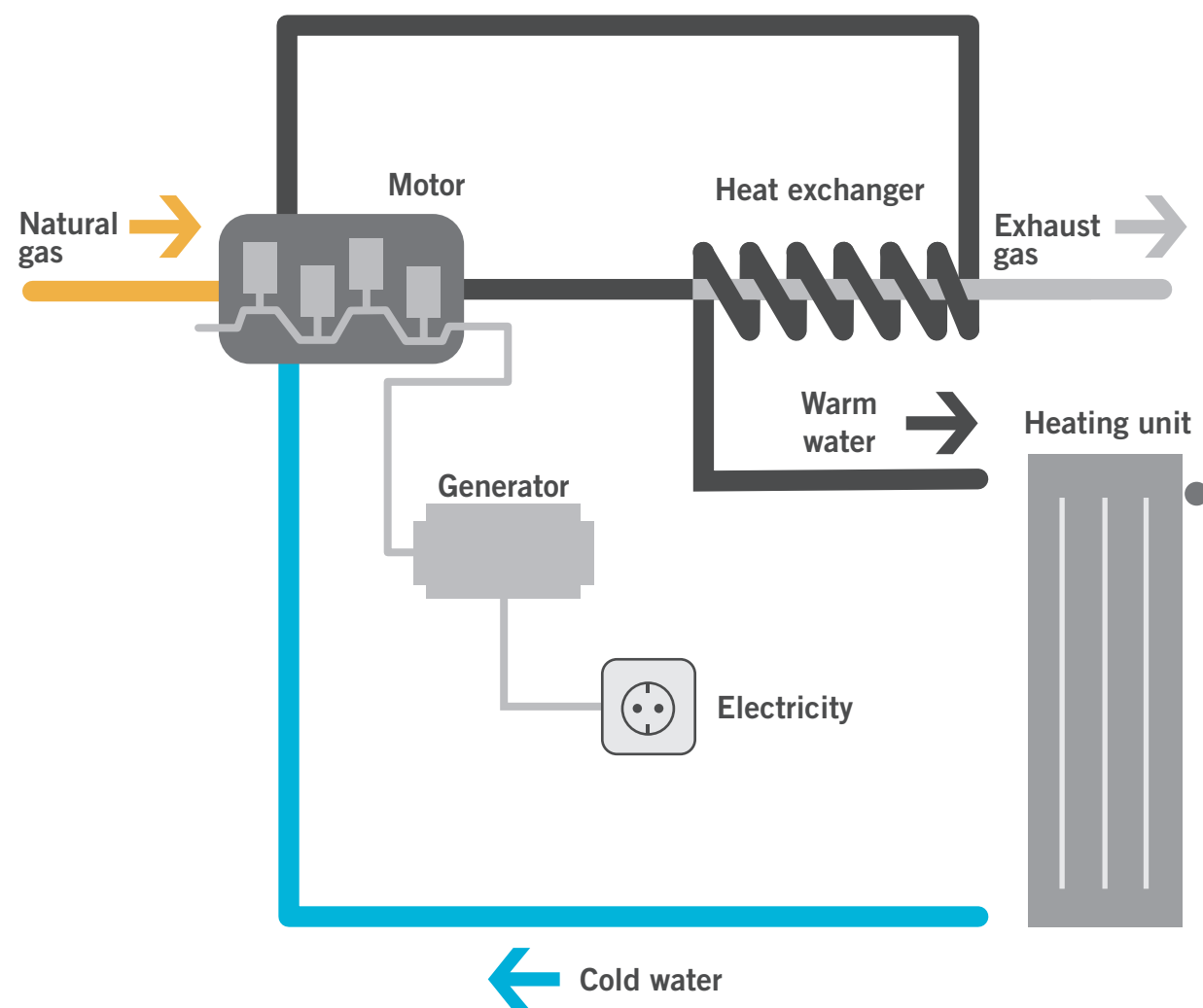

2.1 Electricity and heat from gas – Cogeneration unit

The pioneering technology of cogeneration is highly efficient at generating heat and electrical energy from natural gas. Cogeneration units have been successfully installed at our sites in Paderborn and Korbach. At the Paderborn plant, energy is generated all year round with a thermal output of 480 kW and electrical output of 450 kW. The cogeneration process has an overall effectiveness of up to 90%, which is reviewed annually during our energy audit.

2.2 Electricity from solar energy – Photovoltaics

Photovoltaic systems combine a variety of ecological advantages and have a highly positive influence on energy and environmental footprint. The EROEI factor is ten, meaning ten times as much electricity is generated as is needed for its production. Photovoltaic systems reduce the overall sum of CO₂ emitted during energy production, have a

lifespan of up to 30 years, and is 95% recyclable, thanks to base materials like silicon, glass and aluminium. Currently, we are in the process of equipping all our sites with a total output of 1,200 kWp, which makes up approx. 10% of the Vauth-Sagel Group's total energy requirement.



” Photovoltaic systems reduce the overall sum of CO₂ emitted during energy production, have a lifespan of up to 30 years, and is 95% recyclable, thanks to base materials like silicon, glass and aluminium.

02

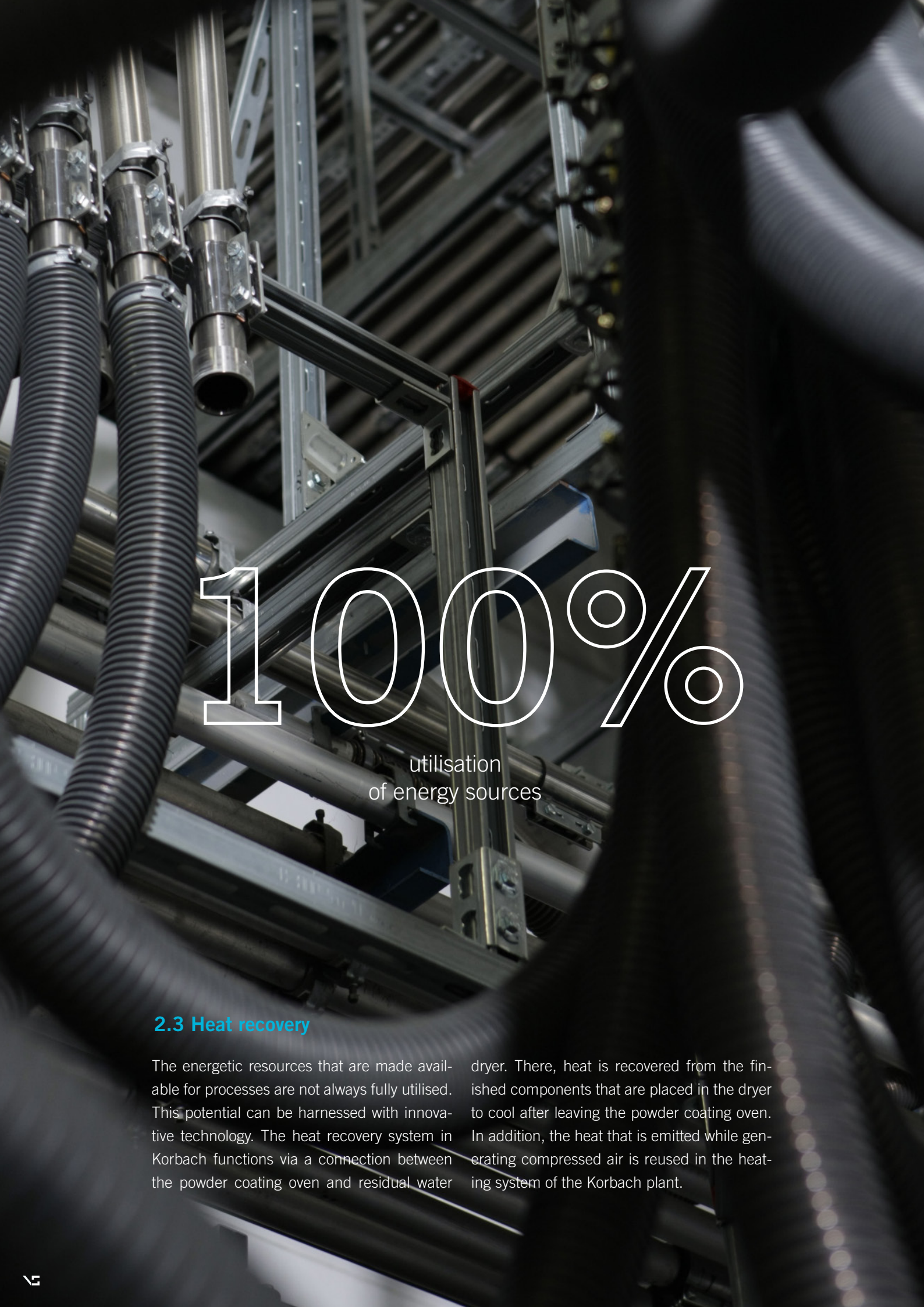

100%

utilisation
of energy sources

2.3 Heat recovery

The energetic resources that are made available for processes are not always fully utilised. This potential can be harnessed with innovative technology. The heat recovery system in Korbach functions via a connection between the powder coating oven and residual water

dryer. There, heat is recovered from the finished components that are placed in the dryer to cool after leaving the powder coating oven. In addition, the heat that is emitted while generating compressed air is reused in the heating system of the Korbach plant.

” It cannot be right to manufacture billions of objects that are used for a matter of minutes, and are then with us for centuries.

ROZ SAVAGE



2.4 Nothing wasted – Recycling waste for energy production

Usually, waste is recycled. In our wood processing department at the Beverungen plant, waste wood is recycled to generate energy, which is used to supply heat.

22

USING RAW MATERIALS INTELLIGENTLY

USING ENVIRONMENTALLY FRIENDLY MATERIALS

03 // One goal of a circular economy is to fully recycle products and reuse all the resulting secondary raw materials in production to close the material cycle. We take this goal into account in everything we do, starting with product development and the selection of materials, all the way through to the systematic processing and recycling of plastics and metals in our production. What's more, we prioritise environmentally friendly materials and efficient processes such as powder coating.

All bins in the
VS ENVI® waste sorting
system are up to

100%

recyclable.

” All the steel furniture we produce can be recycled without loss of quality, meaning they are not only attractive design objects, but also valuable resources for a sustainable, circular economy.

3.1 Everything stays in the cycle – Secondary raw materials

The Vauth-Sagel Group manufactures products made of steel, combined with other materials. Since the primary extraction of steel consumes a vast amount of resources, it goes without saying that we use multi-recycled steel in our production, up to half of which is composed of scrap material. All the steel products we produce, such as the furniture from our subsidiary mauser, can be recycled without loss of quality, meaning they are not only attractive design

objects, but also valuable resources for a sustainable, circular economy. Like steel, plastic also has excellent recycling properties. Products made of 100% recycled material have long been available in various industries. The Vauth-Sagel Group is working on this too; for example, all the bins in our VS ENVI® waste sorting system are 100% recyclable. Internally, defective containers are converted to ground granules and fully reused in production.

03

35 %

REDUCTION IN MATERIAL CONSUMPTION

3.2 Thin coating, big effect – Powder coating

Powder over paint. A major problem with painting processes is the processing of solvents, which do not readily biodegrade and are extremely harmful to the environment and the ozone layer. Powder coating technology, which is completely solvent-free, offers a sustainable, resource-efficient alternative. In 2019, we commissioned one of the biggest powder coating facilities in Europe at our Korbach site with an investment of 8 million euros. Thanks to the thin coating technology, we have reduced our material consumption by 35% and saved the CO₂ equivalent of 730 tons per year through reduced energy consumption.



30

PREVENTING WASTE

REDUCING OUR ENVIRONMENTAL IMPACT

04 // As well as conserving resources, we are dedicated to preventing waste in general, especially environmentally polluting waste products such as solvents and paints. We assess and systematically improve everything we do with this in mind. One good example of this is the complete overhaul of our shipping packaging. Less material consumption, better utilisation of storage space and 100% recyclability are an impressive result for our customers and the environment.

VAUTH
SAGEL

VAUTH
SAGEL
QUALITY
MADE IN GERMANY
www.vauth-sagel.com



3,000 m²



4.1 Paint and solvent replaced with powder

By investing in one of the most advanced powder coating facilities in Europe, we were able to replace conventional painting processes with powder coating at our Korbach plant. The advantages of the 3,000 m² facility speak for themselves: Unlike zinc phosphate coating, powder coating is free of heavy metals, preventing the build-up of sludge in the environment. The innovative, extra-thin coating consumes 35% less resources, i.e. paint. This process completely eliminates the need for non-biodegradable solvents.

04

RECYCLABLE

100%

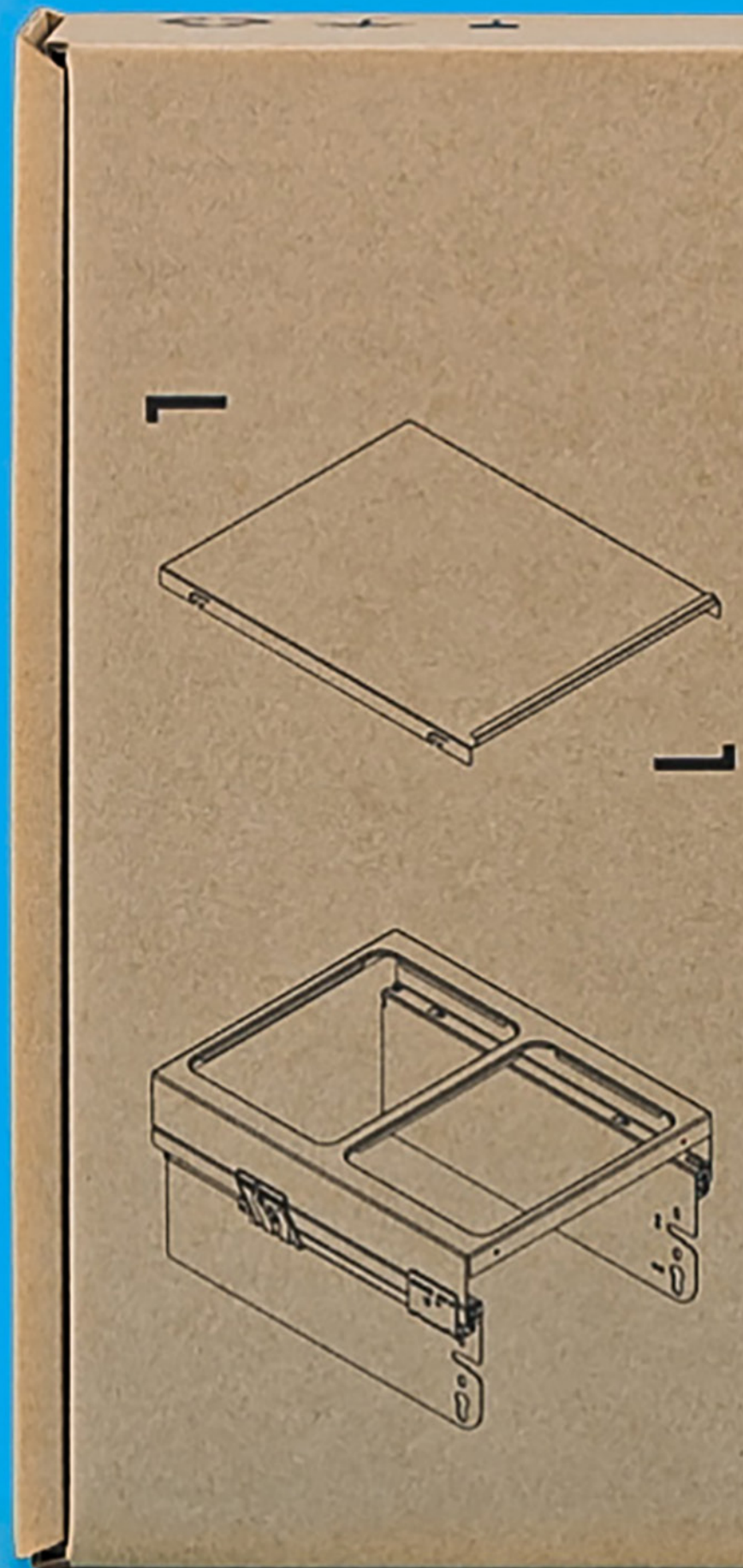

4.2 Sustainable packaging is well-received

Every day, our plants dispatch countless shipments using a variety of methods. For several reasons, we have fully revised, standardised and optimised the packaging we use. It goes without saying that we want to ensure that our products reach the customer safely and in one piece. However, we also consider the environmental aspect in our packaging designs. Our new packaging

contains only as much material as necessary and as little material as possible. This makes it more easily stackable, less bulky during transport, and 100% recyclable. Where possible, we do not fill our packages with packaging film, which are often thrown away by the recipient. For recurring shipments, we use deposit systems such as module boxes to avoid creating waste.

04

CREATING VALUE

DEVELOPING SUSTAINABLE PRODUCTS

05 // The development of our products offers countless opportunities to consider the ecological and sustainable aspect of the product design. Robust and durable products are sustainable simply due to the fact that they do not need to be replaced and disposed of prematurely. A clever, functional design affects the quantity of raw materials and the efficient utilisation of transport space. Full recyclability is a decisive criterion in the selection of product materials.

5.1 Made in Germany – Long-lasting products

The robust steel furniture from our subsidiary mauser is built to last for decades. Many of the models are design classics today and everything other than examples of the throw-away economy. The same is true of all other products from the Vauth-Sagel Group: quality made in Germany is non-negotiable and therefore innately sustainable. Thanks to this certified quality, Vauth-Sagel storage space solutions enhance kitchens and interiors around the world.

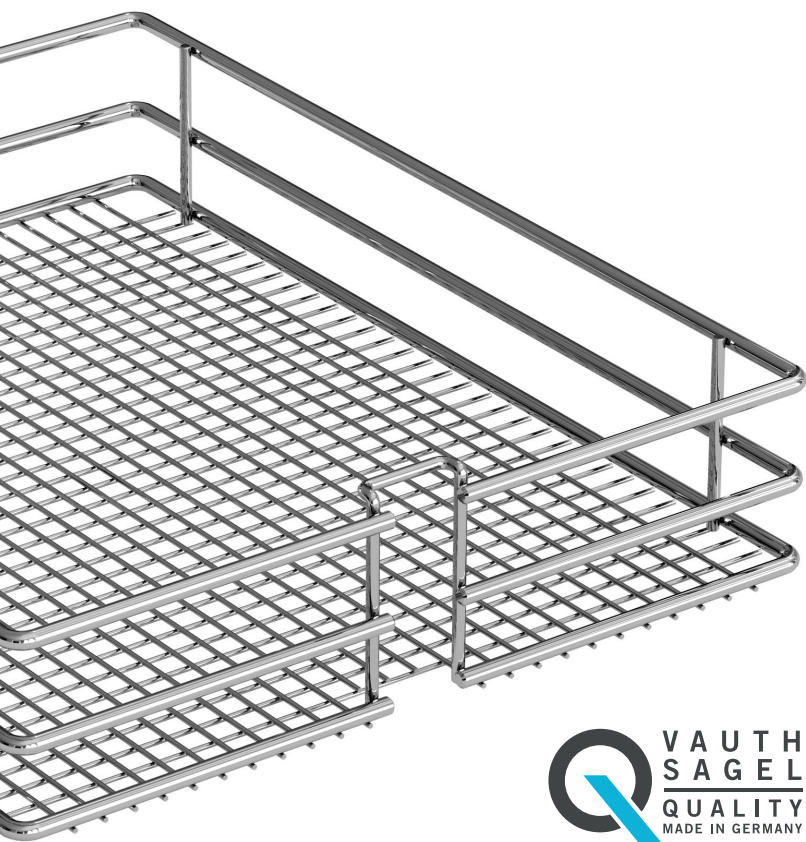

” We want to enable people to make their homes more comfortable and rediscover space at a superior level. For everyone, all over the world!

50



” Vauth-Sagel products offer maximum form and function, combined with minimal impact on the environment.



5.2 The efficiency of design – Resource-efficient products

Many of our products and solutions are designed to make spaces easier and more convenient for people to use. The efficiency of the product design, which shouldn't consume more space than functionally required, also plays a role in this regard. Reducing the de-

sign to the essentials measurably saves raw materials and resources, as well as increasing transport efficiency. Designed on this basis, Vauth-Sagel products offer maximum form and function, combined with minimal impact on the environment.

50

HELPING THE ENVIRONMENT

SUPPORTING A WORLD WORTH LIVING IN

06 // Protecting and advancing environmental interests is part of Vauth-Sagel's DNA. We are pleased to support initiatives that are dedicated to the same goals.

50



1,000
trees planted

6.1 A tree for every visitor – Plant for the Planet

During interzum 2021, we supported the initiative Plant for the Planet for the first time by planting a tree for every visitor of our virtual trade fair platform, VSLive!. By doing so, we and our visitors managed to plant a

total of 1,000 trees. We will continue to support the initiative in future and have made it our goal to invest a further 100,000 euros in the planting of trees worldwide, together with our customers and partners.

” We will continue to support the initiative in future and have made it our goal to invest a further 100,000 euros in the planting of trees worldwide, together with our customers and partners.



90

SEIZING THE FUTURE

IMPLEMENTED IN EVERY VAUTH-SAGEL COMPANY

07 // An overview of all the current sustainability measures that we have already implemented at our sites or are currently in preparation.



VS Systemtechnik GmbH & Co. KG

- Conversion from heating oil to natural gas
- Heat pump operation for heating and cooling in Plant 2, Erkeln
- Recycling of waste wood to generate energy at the Beverungen plant
- Conversion of all the lighting to LED technology, incl. motion sensors and daylight control
- Installation of charging infrastructure for electromobility

IN PREPARATION

- Installation of a 400 kW photovoltaic system in Erkeln and 135 kW in Beverungen
- Heat recovery in powder coating to reduce natural gas consumption
- Digital data tracking of all energy flows
- Improving the energy efficiency of the compressed air supply



VS Logistik GmbH & Co. KG

- Continual replacement of the HGV fleet
- Telematics system for continuous management and optimisation of routes and consumption
- Introduction of electric vehicles to the car fleet
- Installation of charging infrastructure for electromobility

IN PREPARATION

- Trialling of electric HGVs



Westo Kunststofftechnik GmbH

- Highly efficient energy supply system, incl. cogeneration unit for heat/cooling and electricity generation
- Building control technology, incl. heating control
- Continual replacement of machinery
- Conversion of all the lighting to LED technology, incl. motion sensors and daylight control
- Installation of charging infrastructure for electromobility

IN PREPARATION

- Installation of a +400 kW photovoltaic system
- Improving the energy efficiency of the compressed air supply
- Digital data tracking of all energy flows in the company



mauser Einrichtungssysteme GmbH & Co. KG

- Replacement of the heating system
- Installation of a natural-gas-powered cogeneration unit that efficiently generates heat and electricity
- Replacement of the compressed air supply with speed-controlled compressors
- Introduction of a decentralised cooling supply
- Conversion of the lighting to LED technology
- Replacement and optimisation of the building control and management systems
- New construction of a highly efficient powder coating system

IN PREPARATION

- Installation of a 300 kW photovoltaic system



TAKING RESPONSIBILITY

OUR HSE AND CSR GUIDELINES

08 // As well as protecting the environment, we are actively and systematically committed to the health and safety of our employees, and to tolerance, equality and equal opportunity at every level of our business.





1,000
qualified employees



8.1 Creating value through safety

The people in our company are our most valuable asset. That's why the health and safety of our approx. 1,000 employees is our highest priority. The entire organisation is organised around accident prevention, and health and safety training is a regular, integral component of our company culture.

800



” We should therefore claim, in the name of tolerance, the right not to tolerate the intolerant.

KARL POPPER



8.2 Tolerance, equal opportunity and support

The non-negotiable values of our Group include respect and mutual appreciation. For us, social responsibility means that we promote gender equality, integration, e.g. by employing people from disadvantaged backgrounds, and fight against all forms of discrimination. Our comprehensive training and further education programme offers employees of our company the opportunity for personal development in accordance with their strengths.



ZERTIFIKAT UMWELTMANAGEMENT

Das Unternehmen
VAUTH SAGEL
Westo GmbH & Co. Kunststofftechnik KG
Halberstädter Str. 16
33106 Paderborn
hat für den Geltungsbereich
ein Umweltmanagementsystem nach
DIN EN ISO 14001 : 2015
aufgebaut und in die Praxis umgesetzt.
Alle Energiemengen des Unternehmens werden im
zertifizierten Managementsystem berücksichtigt.
Dieses Zertifikat ist nur gültig in Verbindung mit dem Hauptzertifikat-Nr. 33034/03-21
vom 21. März 2021 bis zum 20. März 2024.

Kassel, 22. März 2021
Dr. Ralf Rieken
Geschäftsführer der Zertifizierungsgesellschaft
ESC Cert GmbH, Teichstraße 14, D-34130 Kassel

Zertifikat-Nr.: 33034/03-21_b

ZERTIFIKAT UMWELTMANAGEMENT

Das Unternehmen
VAUTH SAGEL
Kiesweg 2
37688 Beverungen
hat für den Geltungsbereich
ein Umweltmanagementsystem nach
DIN EN ISO 50001 : 2018
aufgebaut und in die Praxis umgesetzt.
Alle Energiemengen des Unternehmens werden im
zertifizierten Managementsystem berücksichtigt.
Dieses Zertifikat ist nur gültig in Verbindung mit dem Hauptzertifikat-Nr. 33034/03-21
vom 21. März 2021 bis zum 20. März 2024.

Kassel, 22. März 2021
Dr. Ralf Rieken
Geschäftsführer der Zertifizierungsgesellschaft
ESC Cert GmbH, Teichstraße 14, D-34130 Kassel

Zertifikat-Nr.: 37688/03-21

ZERTIFIKAT ENERGIEMANAGEMENT

Das Unternehmen
VAUTH SAGEL
VAUTH-SAGEL Logistik
Neue Str. 27
33034 Brakel-Erkeln
hat für den Geltungsbereich
ein Energiemanagementsystem nach
DIN EN ISO 50001 : 2018
aufgebaut und in die Praxis umgesetzt.
Alle Energiemengen des Unternehmens werden im
zertifizierten Managementsystem berücksichtigt.
Dieses Zertifikat ist nur gültig in Verbindung mit dem Hauptzertifikat-Nr. 33034/03-21
vom 21. März 2021 bis zum 20. März 2024.

Kassel, 22. März 2021
Dr. Ralf Rieken
Geschäftsführer der Zertifizierungsgesellschaft
ESC Cert GmbH, Teichstraße 14, D-34130 Kassel

Zertifikat-Nr.: 33034/03-21_g

ZERTIFIKAT UMWELTMANAGEMENT

Das Unternehmen
VAUTH SAGEL
WESTO GmbH & Co. Kunststofftechnik KG
- Vauth Sagel Gruppe -
Halberstädter Straße 16
33106 Paderborn
Deutschland
hat für den Geltungsbereich
ein Managementsystem konform zu den Anforderungen der ISO 9001 : 2015 betreibt und innerhalb der
Laufzeit des Zertifikats von 3 Jahren auf Konformität überwacht wird.

Die Zertifizierungsstelle TÜV NORD CERT GmbH bestätigt hiermit als Ergebnis der Auditing,
Bewertung und Zertifizierungsentscheidung gemäß ISO/IEC 17021-1:2015, dass die Organisation
ein Managementsystem konform zu den Anforderungen der ISO 9001 : 2015 betreibt und innerhalb der
Laufzeit des Zertifikats von 3 Jahren auf Konformität überwacht wird.

Gültig von 2021-01-19
Gültig bis 2024-01-18

Essen, 2020-12-17

Zertifikat-Registrier-Nr. 44 100 107180
Auditbericht-Nr. 3527 6038

Die Gültigkeit kann unter <https://www.tuev-nord.de/de/unternehmen/zertifizierung/zertifikatsdatenbank> verifiziert werden.

45141 Essen
www.tuev-nord-cert.de

Kassel, 22. März 2021
Dr. Ralf Rieken
Geschäftsführer der Zertifizierungsgesellschaft
ESC Cert GmbH, Teichstraße 14, D-34130 Kassel

Zertifikat-Nr.: 33034/03-21_a

ZERTIFIKAT UMWELTMANAGEMENT

Das Unternehmen
mauser
möbel die mitdenken - seit 1896
Mauser Einrichtungssysteme GmbH & Co. KG
Nordring 25
34497 Korbach
hat für den Geltungsbereich
ein Umweltmanagementsystem nach
DIN EN ISO 14001 : 2015
aufgebaut und in die Praxis umgesetzt.
Alle Energiemengen des Unternehmens werden im
zertifizierten Managementsystem berücksichtigt.
Dieses Zertifikat ist nur gültig in Verbindung mit dem Hauptzertifikat-Nr. 33034/03-21
vom 21. März 2021 bis zum 20. März 2024.

Kassel, 22. März 2021
Dr. Ralf Rieken
Geschäftsführer der Zertifizierungsgesellschaft
ESC Cert GmbH, Teichstraße 14, D-34130 Kassel

Zertifikat-Nr.: 33034/03-21_c

ZERTIFIKAT QUALITÄTSMANAGEMENT

Das Unternehmen
VAUTH SAGEL
VAUTH-SAGEL Holding GmbH & Co. KG
Neue Str. 27
33034 Brakel-Erkeln
hat für den Geltungsbereich
ein Qualitätsmanagementsystem nach
DIN EN ISO 9001 : 2015
aufgebaut und in die Praxis umgesetzt.
Alle Energiemengen des Unternehmens werden im
zertifizierten Managementsystem berücksichtigt.
Dieses Zertifikat ist nur gültig in Verbindung mit dem Hauptzertifikat-Nr. 33034/03-21
vom 21. März 2021 bis zum 20. März 2024.

Kassel, 18. November 2021
Dr. Christoph Pohl
Geschäftsführer der Zertifizierungsgesellschaft
ESC Cert GmbH, Teichstraße 14, D-34130 Kassel

Zertifikat-Nr.: 33034/03-21_d

ZERTIFIKAT UMWELTMANAGEMENT

Das Unternehmen
VAUTH SAGEL
Kiesweg 2
37688 Beverungen
hat für den Geltungsbereich
ein Umweltmanagementsystem nach
DIN EN ISO 14001 : 2015
aufgebaut und in die Praxis umgesetzt.
Alle Energiemengen des Unternehmens werden im
zertifizierten Managementsystem berücksichtigt.
Dieses Zertifikat ist nur gültig in Verbindung mit dem Hauptzertifikat-Nr. 33034/03-21
vom 21. März 2021 bis zum 20. März 2024.

Kassel, 22. März 2021
Dr. Ralf Rieken
Geschäftsführer der Zertifizierungsgesellschaft
ESC Cert GmbH, Teichstraße 14, D-34130 Kassel

Zertifikat-Nr.: 33034/03-21_e

ZERTIFIKAT UMWELTMANAGEMENT

Das Unternehmen
mauser
möbel die mitdenken - seit 1896
Mauser Einrichtungssysteme GmbH & Co. KG
Nordring 25
34497 Korbach
Deutschland
hat für den Geltungsbereich
ein Umweltmanagementsystem nach
DIN EN ISO 14001 : 2015
aufgebaut und in die Praxis umgesetzt.
Alle Energiemengen des Unternehmens werden im
zertifizierten Managementsystem berücksichtigt.
Dieses Zertifikat ist nur gültig in Verbindung mit dem Hauptzertifikat-Nr. 33034/03-21
vom 21. März 2021 bis zum 20. März 2024.

Kassel, 22. März 2021
Dr. Ralf Rieken
Geschäftsführer der Zertifizierungsgesellschaft
ESC Cert GmbH, Teichstraße 14, D-34130 Kassel

Zertifikat-Nr.: 33034/03-21_f

Legal information

All parts of this brochure are the property of Vauth-Sagel. This brochure, or parts of it, may not be reproduced in any form without our permission. We reserve all rights from the copyright law.

No liability is accepted for printing errors and other errors. The measurements provided are not binding. We reserve the right to make constructive and technical changes.

Publisher

Vauth-Sagel | Neue Straße 27 | 33034 Brakel-Erkeln | Germany | Telephone: +49 (0) 5272 601-01
Email: vs@vauth-sagel.com | www.vauth-sagel.com

Date: April 2022 | © by Vauth-Sagel | All rights reserved.

